

M-AUDIO

Studiophile™ **AV 40**

Professional Reference Speaker System



English
User Guide

English	5
Introduction	5
What's in the Box?	5
Studiophile AV 40 Features	6
Installation	7
Placing the Studiophile AV 40	9
Your Studiophile AV 40 Warranty	9
Appendices	10

Introduction

1

Thank you for choosing the Studiophile AV 40 professional desktop multimedia audio monitors. Top recording engineers and producers in studios around the world use M-Audio monitors. Now, with the Studiophile AV 40 monitors, you can enjoy the same professional standard of audio quality right on your desktop.

The Studiophile AV 40 has been designed and tested by veteran audio engineers to meet your needs in a desktop audio monitoring environment. Custom-tuned cabinets, optimized speaker design, and advanced crossover technology deliver the best sound you can get in monitors this size. Complete with magnetic shielding for desktop use, Studiophile AV 40 delivers great audio experiences from your music and multimedia applications. The Studiophile AV 40 monitor is self-powered, directly accepting a line-level signal from a variety of sources.

What's in the Box?

2

Your Studiophile AV 40 box contains:

- Two Studiophile AV 40 speakers (Left and Right)
 - Left:** built-in amp and power supply; volume control, headphone jack, and auxiliary stereo input on the front; main RCA stereo input, 1/4" TRS input and right channel signal output on the back
 - Right:** audio connection from left speaker on back
- One 1/8" stereo mini-to-RCA audio cable for use with the main inputs
- 2-conductor standard (keyed) power cable
- 1/8" stereo to 1/8" stereo audio cable (black color) for use with the "Aux" input
- Tinned bare wire audio cable to send right channel audio to the right speaker (transparent color)
- Acoustic/traction pads for speakers
- Owner's manual

Studiophile AV 40 Features

3



1. Woofer

The woofer unit is 4" in diameter and is magnetically shielded to protect your computer video monitor from interference. It includes a high-temperature voice coil and 4" polypropylene treated paper cone. The woofer delivers balanced mid- and low-frequency response.

2. Tweeter

By employing a specially developed 1" treated silk dome with protective magnetic shielding, the tweeter can deliver an extremely natural response. It minimizes resonance by adapting a unique internal damping technology.

3. Bass Reflex Port

The hole in the rear panel is a bass reflex port. It is designed to discharge very low frequency signals and enhance the overall bass response.

4. Bass-Boost Control

The back panel Bass-Boost control on the Studiophile AV 40 gives you additional low-frequency gain and makes the monitors versatile for different spaces and listening preferences.

5. Enclosure

Along with the other components, the Studiophile AV 40's enclosure plays an important role. In order to provide more stable performance, we used a special medium-density fiberboard (MDF) and unique interior reinforcement designed to absorb vibration and impact generated under extreme conditions. Additionally, our innovative speaker monitor cabinet includes carefully placed acoustic material that makes the Studiophile AV 40 sound much bigger than it is—resulting in a smooth, natural bass response.

6. Stereo Auxiliary Input and Headphone Output

For maximum flexibility, we have included a stereo "Aux" input which allows you to plug in a secondary audio source (such as your portable music player) in addition to the main RCA and 1/4" TRS inputs in the back. The volume control works on all inputs simultaneously. Additionally, there is a stereo headphone output next to the "Aux" jack that mutes the sound coming out of the speakers and redirects it to your headphones.

7. Network & Power Amplifiers

The power amplifiers and crossover network, for the Studiophile AV 40 are specially designed for this woofer and tweeter. The network distributes low-, mid-, and high-frequency audio signals to the proper components in order to minimize distortion and to achieve a balanced sound.

Installation

4

For optimal performance of the Studiophile AV 40, please read the following directions carefully before installation.

Precautions

Connections: Your Studiophile AV 40 monitors have a variety of inputs for use with a multitude of devices. Soundcards or other devices with RCA line outputs (e.g., M-Audio Delta Audiophile 24/96) can be connected to the RCA inputs on your left speaker's back panel. Professional audio devices with balanced or unbalanced 1/4" outputs should be connected to the 1/4" TRS back panel inputs. If your soundcard or portable music player has an 1/8" output, you can connect it to the front panel aux input, using the provided 1/8" to 1/8" cable.

Correct Power Operation: Since the Studiophile AV 40 contains amplifiers, it must be connected to a power outlet using the detachable AC cable that is provided. Before connecting power, please make sure that the On/Off switch on the back of the Studiophile AV 40 is set to the off position.

WARNING! - Use of improper voltage may result in hazardous conditions and/or damage to speaker components not covered by speaker warranty. Please make sure the voltage is set appropriately by checking the the position of the red "AC Select" switch on the back before powering on your speakers.

Acoustic/Traction Pads

In order to minimize vibrations and maximize physical stability, we recommend you use the provided acoustic/traction pads on the bottoms of the Studiophile AV 40 monitors.

Speaker Wire Connections ①

Use the transparent tinned bare wire cable included in the Studiophile AV 40 package to connect the Left and Right speakers via the red /black spring-clip terminals on the back of each speaker.

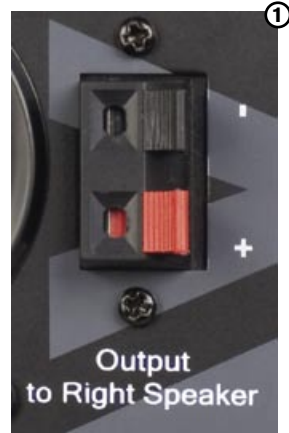

Connecting to a Computer Sound Card or Other Audio Output Device ②

Before connecting the Studiophile AV 40 monitors, make sure the power from the computer or other output device has been turned off and the Studiophile AV 40 system is also turned off.

Connect the 1/4" or RCA input jacks to the corresponding output connectors of a computer sound card, portable music player, etc. You can also use the black 1/8" stereo mini cable to connect a secondary audio device to the "Aux" input on the front of the Studiophile AV 40.

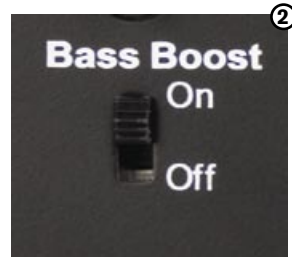

Setting the "Bass Boost" EQ Switch ③

This 2-position switch provides a subtle increase in bass response. The On mode increases the low-frequency gain slightly via the woofer and bass-reflex port. The Off mode produces a natural, even response for most listening conditions.

Please see Appendix C for the "Bass Boost" frequency response curve.



Placing the Studiophile AV 40

5

The way you position your speaker monitors can greatly affect the way they sound. Please refer to the following description for correct Studiophile AV 40 placement.

1. The two speaker monitors and the listener should align to form an equilateral triangle.
2. Ideally, the tops of the woofers should be level with the listener's ears.

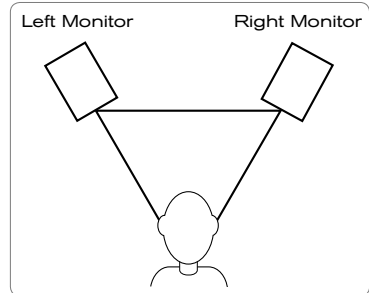

Your Studiophile AV 40 Warranty

6

Warranty Terms

M-Audio warrants products to be free from defects in materials and workmanship, under normal use and provided that the product is owned by the original, registered user. Visit www.m-audio.com/warranty for terms and limitations applying to your specific product.

Warranty Registration

Immediately registering your new M-Audio product entitles you to full warranty coverage and helps M-Audio develop and manufacture the finest quality products available. Register online at www.m-audio.com/register to receive FREE product updates and for the chance to win M-Audio giveaways.

© 2006 Avid Technology, Inc. All rights reserved. Product features, specifications, system requirements and availability are subject to change without notice. Avid, M-Audio and Studiophile AV 40 are either trademarks or registered trademarks of Avid Technology, Inc. All other trademarks contained herein are the property of their respective owners.

Appendices

7

Appendix A - Technical Specifications

Type:	Two-way desktop reference monitor
LF Driver:	4" diameter, magnetically shielded and curved cone with high-temperature voice coil
HF Driver:	1" diameter, magnetically shielded silk dome tweeter
Frequency Response:	85 Hz - 20 kHz
Crossover Frequency:	2.7 kHz
RMS SPL:	101.5dB @ 1 meter
S/N Ratio:	> 90dB (typical, A-weighted)
Input Connectors:	left and right RCA Line input, left and right 1/4" TRS input and 1/8" aux input
Polarity:	positive signal at "+" input produces outward low-frequency cone displacement
Dynamic Power:	20 watts continuous, per channel into 4 Ω
Input Impedance:	10 k Ω unbalanced, 20 k Ω balanced
Input Sensitivity:	100 mV pink noise input produces 90 dBA output SPL at 1 meter with volume control at maximum
Protection:	RF interference, output current limiting, over temperature, turn on/off transient, subsonic filter
Indicator:	Blue power LED ring around volume knob on front panel
Power Requirements:	100-120V/~50/60Hz, 220~240V/~50/60Hz; powered via detachable 2-conductor line cord
Cabinet:	Vinyl-laminated MDF
Dimensions:	8.75" (H) x 6" (W) x 7.25" (D)
Weight:	14 lbs./6.34 kg

Specifications subject to change without notice

Appendix B - Block Diagram

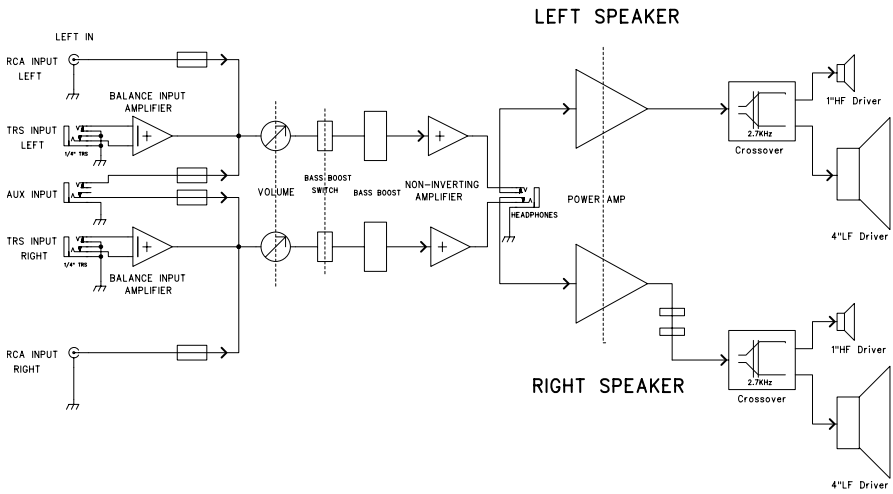

Appendix C - "Bass Boost" Frequency Response Curve

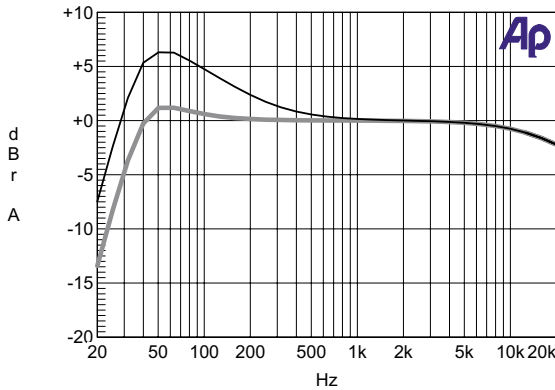

M-Audio USA 5795 Martin Rd., Irwindale, CA 91706	
Technical Support	
web:	www.m-audio.com/tech
tel (pro products):	(626) 633-9055
tel (consumer products):	(626) 633-9066
fax (shipping):	(626) 633-9032
Sales	
e-mail:	sales@m-audio.com
tel:	1-866-657-6434
fax:	(626) 633-9070
Web	www.m-audio.com

M-Audio U.K. Floor 6, Gresham House, 53 Clarendon Road, Watford WD17 1LA, United Kingdom	
Technical Support	
e-mail:	support@maudio.co.uk
tel:(Mac support):	+44 (0)1765 650072
tel:(PC support):	+44 (0)1309 671301
Sales	
tel:	+44 (0)1923 204010
fax:	+44 (0)1923 204039
Web	www.maudio.co.uk

M-Audio France Floor 6, Gresham House, 53 Clarendon Road, Watford WD17 1LA, United Kingdom	
Renseignements Commerciaux	
tel :	0 810 001 105
e-mail :	info@m-audio.fr
Assistance Technique	
PC :	0 0820 000 731
MAC :	0 0820 391 191
Assistance Technique	
e-mail :	support@m-audio.fr mac@m-audio.fr
fax :	+33 (0)01 72 72 90 52
Site Web	www.m-audio.fr

M-Audio Germany Kuhallmand 34, D-74613 Ohringen, Germany	
Technical Support	
e-mail:	support@m-audio.de
tel:	+49 (0)7941 - 9870030
fax:	+49 (0)7941 98 70070
Sales	
e-mail:	info@m-audio.de
tel:	+49 (0)7941 98 7000
fax:	+49 (0)7941 98 70070
Web	www.m-audio.de

M-Audio Canada 1400 St-Jean Baptiste Ave. #150, Quebec City, Quebec G2E 5B7, Canada	
Technical Support	
email:	techcanada@m-audio.com
phone:	(418) 872-0444
fax:	(418) 872-0034
Sales	
e-mail:	infocanada@m-audio.com
phone:	(866) 872-0444
fax:	(418) 872-0034
Web	www.m-audio.ca

M-Audio Japan アビッドテクノロジーズ株式会社 エムオーディオ事業部 〒460-0002 愛知県名古屋市中区丸の内 2-18-10 Avid Technology K.K. 2-18-10 Marunouchi, Naka-Ku, Nagoya, Japan 460-0002	
カスタマーサポート (Technical Support)	
e-mail :	win-support@m-audio.jp
e-mail(Macintosh 環境専用) :	mac-support@m-audio.jp
tel :	052-218-0859 (10:00~12:00/13:00~17:00)
セールスに関するお問い合わせ (Sales)	
e-mail:	info@m-audio.jp
tel:	052-218-3375
fax:	052-218-0875
Web	www.m-audio.jp